

Probabilistic Service Life Assessment and Maintenance Planning of Concrete Structures

Fabio Biondini¹; Franco Bontempi²; Dan M. Frangopol, F.ASCE³; and Pier Giorgio Malerba⁴

Abstract: This paper presents a general approach to the probabilistic prediction of the structural service life and to the maintenance planning of deteriorating concrete structures. The proposed formulation is based on a novel methodology for the assessment of the time-variant structural performance under the diffusive attack of external aggressive agents. Based on this methodology, Monte Carlo simulation is used to account for the randomness of the main structural parameters, including material properties, geometrical parameters, area and location of the reinforcement, material diffusivity and damage rates. The time-variant reliability is then computed with respect to proper measures of structural performance. The results of the lifetime durability analysis are finally used to select, among different maintenance scenarios, the most economical rehabilitation strategy leading to a prescribed target value of the structural service life. Two numerical applications, a box-girder bridge deck and a pier of an existing bridge, show the effectiveness of the proposed methodology.

DOI: 10.1061/(ASCE)0733-9445(2006)132:5(810)

CE Database subject headings: Concrete structures; Damage; Diffusion; Durability; Nonlinear analysis; Service life; Uncertainty principles; Probability.

Introduction

The structural performance of concrete structures is time-dependent, mainly because of the damaging process induced by the diffusive attack of environmental aggressive agents (CEB 1992). This problem is generally investigated through the study of the local deterioration of the materials, dealing for example with carbonation of concrete and corrosion of reinforcement, and limited attention is devoted to the global effects of these local phenomena on the overall performance of the structure. A durability analysis leading to a reliable assessment of the actual structural service life should be able to account for both the diffusion process and the corresponding mechanical damage, as well as for the coupling effects among diffusion, damage and structural behavior. In a previous paper (Biondini et al. 2004b), a novel deterministic approach to the problem of durability analysis and service life assessment of deteriorating concrete structures in aggressive environments has been presented. In the proposed formulation, the

diffusion process is modeled by using cellular automata and the mechanical damage coupled to diffusion is then evaluated by introducing proper material degradation laws. Since the rate of mass diffusion usually depends on the stress state, the interaction between the diffusion process and the mechanical behavior of the damaged structure is also taken into account by a proper modeling of the stochastic effects in the mass transfer.

Based on this methodology and further developments reported by the writers (Biondini et al. 2004a,c), this paper presents a probabilistic procedure for the evaluation of the time-variant reliability with respect to proper indicators of the structural performance. In this procedure, the structural analysis is formulated at the cross-sectional level and the randomness in the main parameters of the structure (material properties, geometrical dimensions, area and location of the reinforcement, material diffusivity and damage rates) is accounted for by Monte Carlo simulation. The time-variant reliability is then computed with reference to proper indicators of structural performance.

In this way, the actual structural lifetime of deteriorating concrete structures can be predicted in probabilistic terms. On the other hand, the results of the durability analysis can also allow to plan maintenance of the structure in order to achieve a prescribed target value of the structural lifetime under prescribed reliability levels. In particular, based on a comparison among the costs of maintenance associated with different scenarios of essential and/or preventive interventions, a proper rehabilitation strategy can be finally selected.

Numerical applications to a box-girder bridge deck and to a pier of an existing bridge show the effectiveness of the proposed methodology.

Time-Variant Performance of Concrete Structures in Aggressive Environments

In the following a novel approach to the problem of durability analysis and service life assessment of concrete structures sub-

¹Associate Professor, Dept. of Structural Engineering, Politecnico di Milano, Piazza L. da Vinci, 32-20133 Milan, Italy (corresponding author). E-mail: biondini@stru.polimi.it

²Professor, Dept. of Structural and Geotechnical Engineering, Univ. of Rome "La Sapienza," Via Eudossiana 18-00184 Rome, Italy. E-mail: franco.bontempi@uniroma1.it

³Professor, Dept. of Civil, Environmental, and Architectural Engineering, Univ. of Colorado, CB 428, Boulder, CO 80309-0428. E-mail: dan.frangopol@colorado.edu

⁴Professor, Dept. of Structural Engineering, Politecnico di Milano, Piazza L. da Vinci, 32-20133 Milan, Italy. E-mail: malerba@stru.polimi.it

Note. Associate Editor: Shahram Sarkani. Discussion open until October 1, 2006. Separate discussions must be submitted for individual papers. To extend the closing date by one month, a written request must be filed with the ASCE Managing Editor. The manuscript for this paper was submitted for review and possible publication on August 20, 2004; approved on January 12, 2005. This paper is part of the *Journal of Structural Engineering*, Vol. 132, No. 5, May 1, 2006. ©ASCE, ISSN 0733-9445/2006/5-810-825/\$25.00.

jected to the diffusive attack from external aggressive agents is briefly summarized. Additional details can be found in Biondini et al. (2004b).

Simulation of Diffusion Processes in Aggressive Environments

As known, the simplest model to describe the kinetic process of diffusion of chemical components in solids is represented by the Fick's laws, which, in the case of a single component diffusion in isotropic, homogeneous and time-invariant media, can be reduced to the following second order partial differential linear equation (Glicksman 2000):

$$D\nabla^2 C = \frac{\partial C}{\partial t} \quad (1)$$

where D =diffusivity coefficient of the medium; $C=C(\mathbf{x}, t)$ =concentration of the component at point \mathbf{x} and time t ; $\nabla C=\mathbf{grad} C(\mathbf{x}, t)$; and $\nabla^2=\nabla \cdot \nabla$. From the numerical point of view, such equation can be effectively simulated by using cellular automata which, in their basic form, consists of regular uniform grids of *sites* or *cells*, theoretically having infinite extension, with a discrete variable in each cell which can take on a finite number of states (Wolfram 1994). In particular, the Fick's laws in d dimensions ($d=1, 2, 3$) can be reproduced by adopting the following evolutionary rule (Biondini et al. 2004b):

$$C_i^{k+1} = \phi_0 C_i^k + \sum_{j=1}^d (\phi_j^- C_{i-1,j}^k + \phi_j^+ C_{i+1,j}^k) \quad (2)$$

where the discrete variable $C_i^k=C(\mathbf{x}_i, t_k)$ represents the concentration of the component in the cell i at time t_k . According to the mass conservation law, the values of the evolutionary coefficients must verify the following *normality rule*:

$$\phi_0 + \sum_{j=1}^d (\phi_j^- + \phi_j^+) = 1 \quad (3)$$

For isotropic media the symmetry condition $\phi_j^- = \phi_j^+ = \phi_1$ ($j=1, \dots, d$) must be also satisfied. Moreover, to regulate the process according to a given diffusivity D , a proper discretization in space and time should be chosen in such a way that the grid dimension Δx and the time step Δt satisfy the following relationship:

$$D = \frac{1 - \phi_0}{2d} \frac{\Delta x^2}{\Delta t} = \phi_1 \frac{\Delta x^2}{\Delta t} \quad (4)$$

The deterministic values $\phi_0=1/2$ and $\phi_1=1/(4d)$ usually lead to a good accuracy of the automaton. This has been proven in one-, two- and three-dimensional problems (Ardigò and Motta 2002). However, stochastic effects in the diffusion process can be usefully included in order to account for the coupling effects between diffusion and damage. To this aim, the evolutionary coefficients ϕ cannot be longer considered as deterministic quantities but are instead assumed as random variables Φ with given probability density distributions $f_\Phi(\phi)$. In particular, it is convenient to denote $\Phi=(1+\Psi)\phi$, where the coefficients ϕ maintain the original deterministic values, and Ψ =random variables whose outcomes $\psi \in [-1; 1]$ describe the stochastic part of diffusion. Moreover, for the probability density functions $f_\Psi(\psi)$ a simple, but also very effective, triangular shaped distribution with bounds $[\psi_a; \psi_b]$ and mode ψ_c can be assumed (Biondini et al. 2004b). Clearly, symmetrical functions with $\psi_c=0$ must be adopted in

order to avoid directionality effects in the stochastic model. However, skewed distributions $\psi_c \neq 0$ can also successfully be applied to simulate local modifications in the rate of mass diffusion induced by mechanical stress states. In concrete structures, for example, cracking usually favors higher gradient of concentration. This phenomenon may be accounted for by adopting in the regions of cracked concrete skewed distributions with $\psi_c > 0$, which on the average tend to increase the local diffusivity, while in the regions of undamaged material symmetrical functions with $\psi_c=0$ still hold.

Modeling of Damage Evolution

Structural damage is modeled by introducing a degradation law of the effective resistant area for both the concrete matrix $A_c=A_c(t)$ and the steel bars $A_s=A_s(t)$:

$$dA_c(t) = [1 - \delta_c(t)] dA_{c0} \quad (5)$$

$$dA_s(t) = [1 - \delta_s(t)] dA_{s0} \quad (6)$$

where the subscript "0" denotes the undamaged state at the initial time $t=t_0$; and the dimensionless functions $\delta_c=\delta_c(t)$ and $\delta_s=\delta_s(t)$ represent *damage indices* which provide a direct measure of the damage level within the range $[0; 1]$.

The damage process clearly depends on the time evolution of diffusion (CEB 1992). In particular, damage rates are clearly related to the concentration of the aggressive agent. Despite the complexity of such relationship at the microscopic level, very simple coupling models can often be successfully adopted at the macroscopic level in order to reliably predict the structural service life. Following this view, the damage indices $\delta_c=\delta_c(\mathbf{x}, t)$ and $\delta_s=\delta_s(\mathbf{x}, t)$ are here correlated to the diffusion process by assuming, for both materials, a linear relationship between the rate of damage and the mass concentration $C=C(\mathbf{x}, t)$ of the aggressive agent:

$$\frac{\partial \delta_c(\mathbf{x}, t)}{\partial t} = \frac{C(\mathbf{x}, t)}{C_c \Delta t_c} \quad (7)$$

$$\frac{\partial \delta_s(\mathbf{x}, t)}{\partial t} = \frac{C(\mathbf{x}, t)}{C_s \Delta t_s} \quad (8)$$

where C_c and C_s represent the values of constant concentration $C(\mathbf{x}, t)$ which lead to a complete damage of the materials after the time periods Δt_c and Δt_s , respectively. In addition, the initial conditions $\delta_c(\mathbf{x}, t_{cr})=\delta_s(\mathbf{x}, t_{cr})=0$ with $t_{cr}=\max\{t | C(\mathbf{x}, t) \leq C_{cr}\}$ are assumed, where C_{cr} =critical threshold of concentration (Biondini et al. 2004b).

Structural Analysis of Deteriorating Reinforced Concrete Cross Sections

The previous general criteria are now applied to the durability analysis of reinforced concrete cross sections. The formulation assumes the linearity of concrete strain field and neglects the bond slip of reinforcement. The vectors of the stress resultants (axial force N and bending moments M_z and M_y):

$$\mathbf{r} = \mathbf{r}(t) = [N \ M_z \ M_y]^T \quad (9)$$

and of the global strains (axial elongation ϵ_0 and bending curvatures χ_z and χ_y):

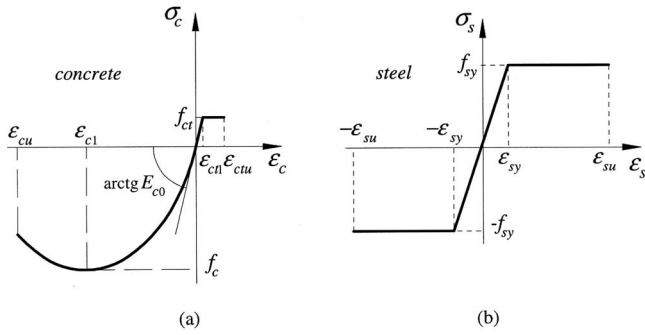

Fig. 1. Constitutive laws of the materials: (a) concrete and (b) reinforcing steel

$$\mathbf{e} = \mathbf{e}(t) = [\varepsilon_0 \chi_z \chi_y]^T \quad (10)$$

are then related, at each time instant t , as follows (Malerba 1998):

$$\mathbf{r}(t) = \mathbf{H}(t)\mathbf{e}(t) \quad (11)$$

The stiffness matrix $\mathbf{H} = \mathbf{H}(t)$ is derived by integration over the area of the composite cross section, or by assembling the contributions of both concrete $\mathbf{H}_c = \mathbf{H}_c(t)$ and steel $\mathbf{H}_s = \mathbf{H}_s(t)$:

$$\mathbf{H}(t) = \mathbf{H}_c(t) + \mathbf{H}_s(t) \quad (12)$$

$$\mathbf{H}_c(t) = \int_{A_c} E_c(y, z, t) \mathbf{b}(y, z)^T \mathbf{b}(y, z) [1 - \delta_c(y, z, t)] dA \quad (13)$$

$$\mathbf{H}_s(t) = \sum_m E_{sm}(t) \mathbf{b}_m^T \mathbf{b}_m [1 - \delta_{sm}(t)] A_{sm} \quad (14)$$

where the symbol “ m ” refers to the m th steel bar located at $\mathbf{x}_m = (y_m, z_m)$; $E_c = E_c(y, z, t)$ and $E_{sm} = E_{sm}(t)$ are the secant moduli of the materials; and $\mathbf{b}(y, z) = [1 - y \ z]^T$. It is worth noting that the vectors \mathbf{r} and \mathbf{e} have to be considered as total or incremental quantities depending on the nature of the stiffness matrix \mathbf{H} , which depends on the type of formulation adopted (i.e., secant or tangent) for the generalized moduli of the materials.

The constitutive laws adopted in this study are shown in Fig. 1. For concrete, the stress–strain diagram is described by the Saenz’s law in compression and by an elastic perfectly plastic model in tension. By denoting f_c the compression strength of the material, the following parameters are assumed: tension strength $f_{ct} = 0.25|f_c|^{2/3}$ [MPa]; initial modulus $E_{c0} = 9500|f_c|^{1/3}$ [MPa]; peak strain in compression $\varepsilon_{c0} = -0.20\%$; strain limit in compression $\varepsilon_{cu} = -0.35\%$; strain limit in tension $\varepsilon_{ctu} = 2f_{ct}/E_{c0}$. For steel, the stress–strain diagram is described by an elastic perfectly plastic model in both tension and compression with yielding strength f_{sy} , elastic modulus $E_s = 206$ GPa, and strain limit $\varepsilon_{su} = 1.00\%$. In this way, the constitutive laws are fully defined by the material strengths f_c and f_{sy} .

Structural Reliability and Maintenance Strategies

Probability of Failure and Reliability Index

Let $R = R(t)$ and $S = S(t)$ be proper time-variant measures of the structural resistance and demand, respectively. Because of the uncertainties in material and geometrical properties, in the physical models of diffusion and damage, and in the mechanical and environmental stressors, both functions $R = R(t)$ and $S = S(t)$ have to

be considered as random variables or processes. A measure of the time-variant structural performance is realistically possible only in probabilistic terms. In particular, by denoting r_k and s_k the outcomes of the random variables $R_k = R(t_k)$ and $S_k = S(t_k)$, respectively, the probability of failure at given time instants $t = t_k$ can be evaluated by the integration of the joint density function $f_{R,S}^k(r_k, s_k)$ within the failure domain $D_k = \{r_k, s_k | r_k < s_k\}$:

$$P_F(t_k) = P[R_k < S_k] = \int_{D_k} f_{R,S}^k(r_k, s_k) dr ds \quad (15)$$

Alternatively, the structural safety can also be measured by means of the reliability index $\beta = \beta(t)$:

$$\beta(t_k) = \frac{\mu_{R,k} - \mu_{S,k}}{\sqrt{\sigma_{R,k}^2 + \sigma_{S,k}^2 - 2\rho_k \sigma_{R,k} \sigma_{S,k}}} \quad (16)$$

where μ and σ = mean and standard deviation values, respectively; and ρ = correlation coefficient between R and S .

In practice the above joint density function of R and S is not known, and at most some information is available about a set of N basic random variables $\mathbf{X} = [X_1 \ X_2 \ \dots \ X_N]^T$ which defines the structural problem at the initial time $t = t_0$ (e.g., material properties, geometrical dimensions, area and location of the reinforcement, etc.). Moreover, in concrete design the levels of verification are usually formulated in terms of functions of random variables $\mathbf{Y} = \mathbf{Y}(\mathbf{X})$ which describe the structural response at each time instant $t = t_k$ (e.g., stress resultants \mathbf{r} , global strains \mathbf{e} , etc.), and such derivation is generally only available in an implicit form. A numerical approach is then required and the reliability analysis can be performed by Monte Carlo simulation.

Service Life Assessment

The probabilistic approach presented previously can be also applied to evaluate the actual service life T_a of the structure:

$$T_a = \min\{(t - t_0) | R \geq S, \forall t \geq t_0\} \quad (17)$$

where t_0 = time instant at the end of the construction phase. In particular, the limit threshold T_a^* of the random variable T_a associated with a prescribed target reliability level, for example expressed in terms of acceptable values of probability of failure P_F^* or reliability index β^* , can be directly computed as follows:

$$\begin{aligned} T_a^* &= \min\{(t - t_0) | P_F \leq P_F^*, \forall t \geq t_0\} \\ &= \min\{(t - t_0) | \beta \geq \beta^*, \forall t \geq t_0\} \end{aligned} \quad (18)$$

Maintenance Planning

The results of the probabilistic analysis can also allow to plan a rehabilitation of the structure in order to achieve a given design value of the structural lifetime $T_d \geq T_a^*$. The reliability index $\beta(t)$ of the rehabilitated structure can be obtained by superposing the initial reliability index $\beta_0(t)$ and its increments $\Delta\beta_i(t)$ associated with the subsequent interventions $i = 1, \dots, n$ (Kong and Frangopol 2003):

$$\beta(t) = \beta_0(t) + \sum_{i=1}^n \Delta\beta_i(t) \quad (19)$$

Different maintenance scenarios with essential and/or preventive interventions leading to different $\Delta\beta_i(t)$ can be considered in order to achieve the desired value of service life T_d (Neves et al.

Table 1. Probability Distribution and Their Parameters

Random variable ($t=t_0$)	Distribution type	μ	σ
Concrete strength, f_c	Lognormal	$f_{c,nom}$	5 MPa
Steel strength, f_{sy}	Lognormal	$f_{sy,nom}$	30 MPa
Coordinates of the nodal points, (y_i, z_i)	Normal	$(y_i, z_i)_{nom}$	5 mm
Coordinates of the steel bars, (y_m, z_m)	Normal	$(y_m, z_m)_{nom}$	5 mm
Diameter of the steel bars, \varnothing_m	Normal ^a	$\varnothing_{m,nom}$	$0.10\varnothing_{m,nom}$
Diffusivity coefficient, D	Normal ^a	D_{nom}	$0.10D_{nom}$
Concrete damage rate, $q_c=(C_c\Delta t_c)^{-1}$	Normal ^a	$q_{c,nom}$	$0.30q_{c,nom}$
Steel damage rate, $q_s=(C_s\Delta t_s)^{-1}$	Normal ^a	$q_{s,nom}$	$0.30q_{s,nom}$

^aTruncated distributions with non-negative outcomes are adopted in the simulation process.

2003). For each scenario the total cost of maintenance C can be evaluated by summing the costs C_i of the individual interventions:

$$C = \sum_{i=1}^n \frac{C_i}{(1+v)^{t_i}} = \sum_{i=1}^n C_{0i} \quad (20)$$

where the cost C_i of the i th rehabilitation has been referred to the initial time t_0 by taking a proper discount rate of money v into account.

In this way, based on a comparison among the costs of maintenance associated with different scenarios, a proper rehabilitation strategy can be finally selected.

Applications

In the following two numerical applications, a box-girder bridge deck and a pier of an existing bridge, are presented in order to show the effectiveness of the proposed methodology. In both cases, the probabilistic model assumes as random variables the material strengths f_c and f_{sy} , the coordinates (y_p, z_p) of the nodal points $p=1, 2, \dots$ which define the two-dimensional model of the concrete cross section, the coordinates (y_m, z_m) and the diameter \varnothing_m of the steel bars $m=1, 2, \dots$, the diffusivity coefficient D and the damage rates $q_c=(C_c\Delta t_c)^{-1}$ and $q_s=(C_s\Delta t_s)^{-1}$. These variables are assumed to have the probabilistic distribution with the mean and standard deviation values listed in Table 1. Based on this model, a reliability analysis is performed by Monte Carlo simulation. The sampling error is reduced by the antithetic variables technique, while a posteriori estimation on the goodness of the sample size M is based on a monitoring of the function $\beta_k(M)=\beta(t_k, M)$ for each time instant t_k of interest.

In order to clarify the validity and accuracy of the probabilistic model just introduced, two aspects need to be further addressed. First, despite the fact that the uncertainty associated with randomness of the variability of the critical threshold C_{cr} may have a remarkable influence on the actual development of the damage process, especially on the initiation time of steel corrosion, the worst scenario with $C_{cr}=0$ only is considered. Second, the time-dependent variability of bridge loading is not included in the model and simplified assumptions on its probabilistic distribution are made. However, the investigation of both such aspects is outside the purpose of this study and may be further emphasized in future works. In this context the presented applications are mainly

aimed to prove that the proposed approach is a powerful engineering tool in both reliability assessment and maintenance planning of deteriorating concrete structures.

Box-Girder Bridge Deck

The application to the service life assessment and maintenance planning of the reinforced concrete box girder deck having the cross section shown in Fig. 2(a) is first considered. The cross section has main nominal dimensions $d_y=2.20$ m and $d_z=7.90$ m, and is reinforced with 220 bars having nominal diameter $\varnothing=26$ mm. The constitutive laws of the materials are defined by a nominal compression strength of the concrete $f_c=-40$ MPa, and by a nominal yielding strength of the steel $f_{sy}=500$ MPa. With reference to a nominal diffusivity coefficient $D=10^{-11}$ m²/s, the cellular automaton is defined by a grid dimension $\Delta x=35.5$ mm and a time step $\Delta t=0.5$ years. Fig. 2(b) shows the location of the aggressive agent, with concentration $C(t)=C_0$ along the bottom side on the left and $C(t)=1/2C_0$ within the cell on the right. Damage rates are defined by the nominal values $C_{cr}=0$, $C_c=C_s=C_0$, $\Delta t_c=5$ years, and $\Delta t_s=7.5$ years. Stochastic effects in the mass transfer are accounted for by assuming $\Psi_b=-\Psi_a=1$, with $\Psi_c=0$ and $\Psi_c=1$ for uncracked and cracked concrete, respectively.

The time evolution of the diffusion process for the *nominal scenario* is described by the map presented in Fig. 2(c), which shows the distribution of concentration $C(x, t)/C_0$ of the aggressive agent after 50 years from the initial time of diffusion penetration. The mechanical damage induced by diffusion can be assessed from diagrams of Fig. 3, which show the time evolution of the structural response in terms of dimensionless diagrams of bending moment M_z versus curvature χ_z , with $N=M_y=0$.

Several parameters could be adopted as suitable measures of the structural performance. With reference to the bending moment versus curvature diagram in Fig. 4, meaningful parameters are for example the bending moment M_z at cracking, yielding and ultimate conditions, as well as the curvature ductility $\varphi=\chi_u/\chi_y$ given by the ratio of curvatures at ultimate and yielding, respectively (Biondini et al. 2004b). With reference to a sample of 5,000 simulations, Fig. 5 shows the time evolution of the statistical parameters (mean value μ , standard deviation σ , minimum and maximum values) of the performance indicators for both positive and negative bending responses during the first 50 years of service life. When directly compared with the randomness of the variability of the structural demand, the results of this simulation allow to compute at each point in time the probability of failure. As an example, Fig. 6 show the probability curves for given deterministic target levels of the structural performance indicators. These curves allow to assess the time-variant reliability of the cross section with respect to required performance or, conversely, to assess the remaining service life which can be assured under prescribed reliability levels.

In addition, as mentioned, the results of the probabilistic analysis can be also used to plan a rehabilitation of the structure in order to achieve a given design value of the structural lifetime. As an example, Fig. 7 refers to the time evolution of the reliability index $\beta(t)$ computed by assuming for the ultimate dimensionless bending moment $m_z=M_z/(|f_c|A_{c0}d_y)$ a structural demand normally distributed with mean $\mu=0.040$, standard deviation $\sigma=0.12\mu$, and correlation coefficient $\rho=0$. With reference to a target level $\beta^*=4.0$, Fig. 7(a) shows three different scenarios of

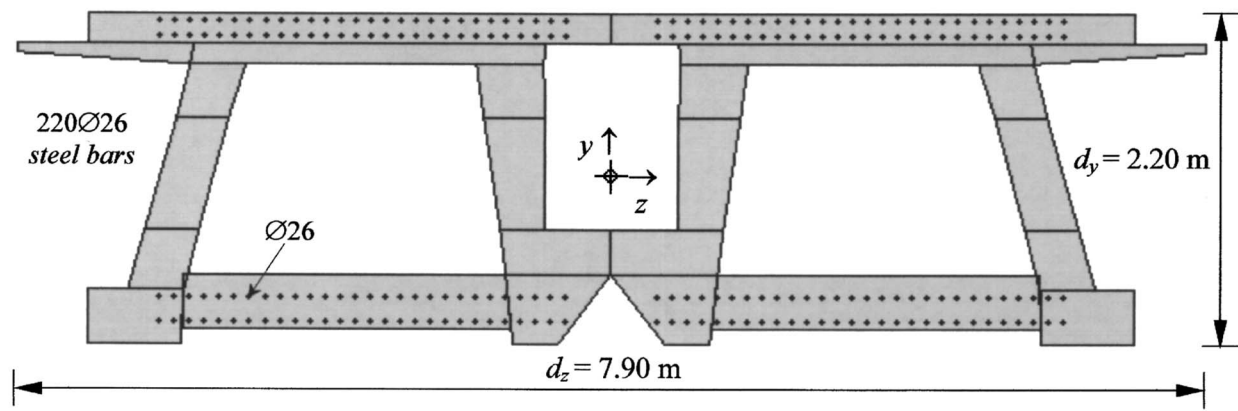

(a)

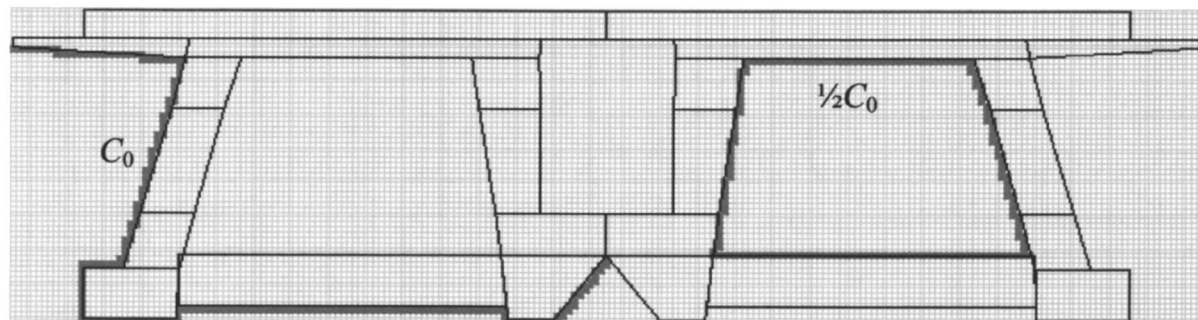

■ Aggressive Agent □ Grid of the Automaton

(b)

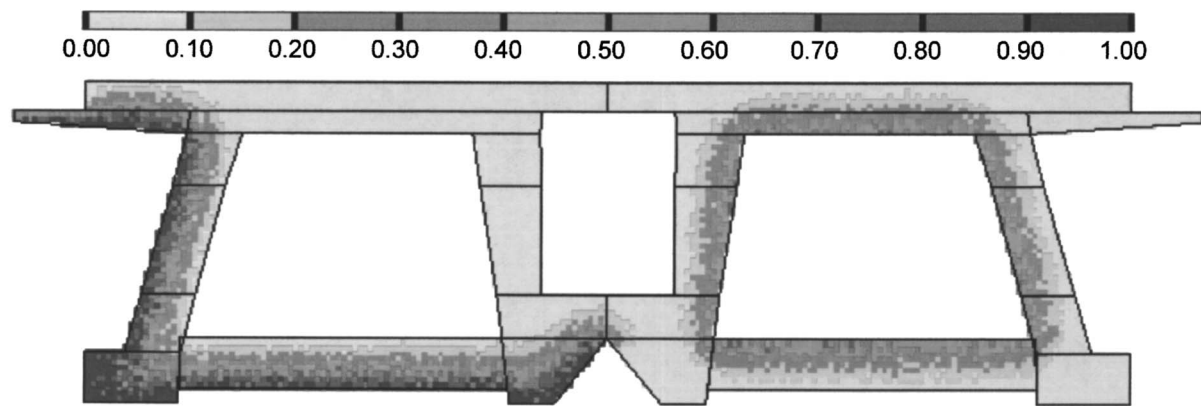

(c)

Fig. 2. Box-girder cross section undergoing diffusion. (a) Geometry and location of the reinforcement. (b) Grid of the cellular automaton and location of the aggressive agent. (c) Distribution of the concentration $C(x,t)/C_0$ of the aggressive agent after 50 years from the initial time of diffusion penetration (nominal scenario).

maintenance aimed to achieve a structural lifetime of at least 50 years. All the scenarios are based on a two-years cycle of inspections, and when the target level β^* is reached or nearly reached, a rehabilitation is made in order to increase the reliability level.

The first scenario assumes essential interventions only, aimed

to restore the initial reliability level β_0 . The second scenario assumes preventive interventions only, applied every 8 years by increasing the reliability level $\Delta\beta=0.85$. Finally, the third scenario assumes a mixed strategy with both essential and preventive interventions. Fig. 7(b) shows the corresponding time-evolution of the cumulative costs C , normalized to the cost C_p of a single

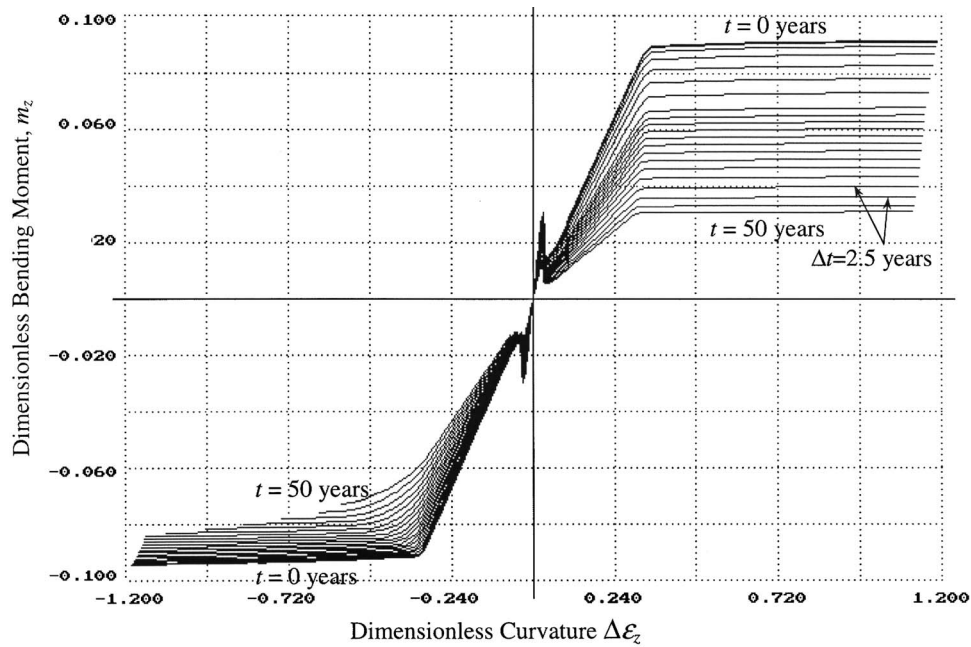

Fig. 3. Box-girder cross section undergoing diffusion. Time-evolution ($\Delta t=2.5$ years) of the dimensionless bending moment $m_z = M_z / (f_c A_{c0} d_y)$ versus curvature $\Delta \varepsilon_z = \chi_z d_y$ diagrams for $N = M_y = 0$ (nominal scenario).

preventive intervention. The cumulative costs are computed by assuming a cost ratio between essential and preventive intervention $C_E/C_P=10$, and a discount rate of money $v=0.06$. The comparison between such diagrams highlights the expected cost-effectiveness of preventive maintenance (Scenario 2).

Pier of an Existing Bridge

The second application refers to the bridge shown in Fig. 8. The bridge was designed by Martinez Y Cabrera (2002). The probabilistic analysis focuses on the box cross section of the piers

shown in Fig. 9(a), with main nominal dimensions $d_y=8.20$ m and $d_z=9.00$ m. It is reinforced with $160+248=408$ steel bars having nominal diameters $\varnothing=18$ mm and $\varnothing=30$ mm, respectively, as shown in Fig. 9(b). The constitutive laws of the materials are defined by a nominal compression strength of the concrete $f_c=30$ MPa, and by a nominal yielding strength of the steel $f_{sy}=500$ MPa. Fig. 10(a) shows the structural modeling of the cross section. With reference to a nominal diffusivity coefficient $D=10^{-11}$ m²/s, the cellular automaton is defined by a grid dimension $\Delta x=71.0$ mm and a time step $\Delta t=2$ years. Fig. 10(b) shows the grid of the automaton and the location of the aggressive agent, with concentration $C(t)=C_0$ along the external perimeter of the

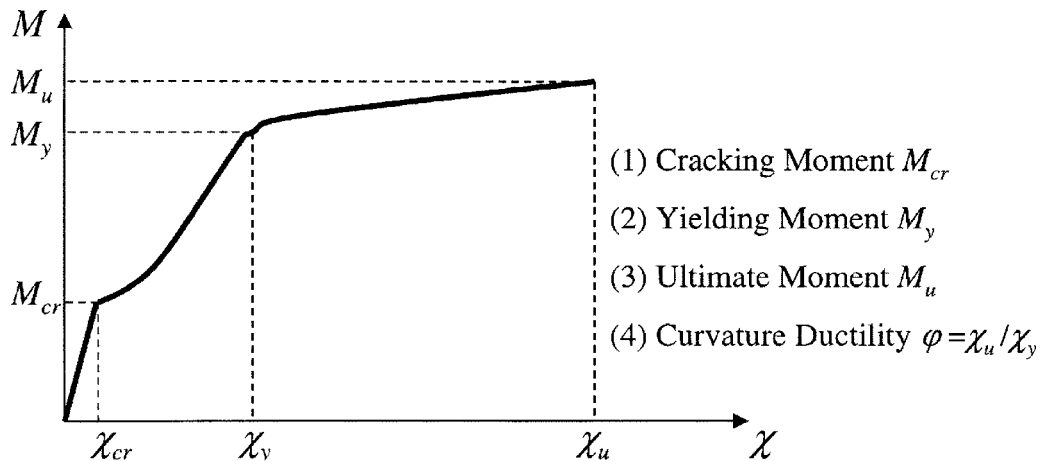

Fig. 4. Structural performance indicators of the bending cross-sectional response

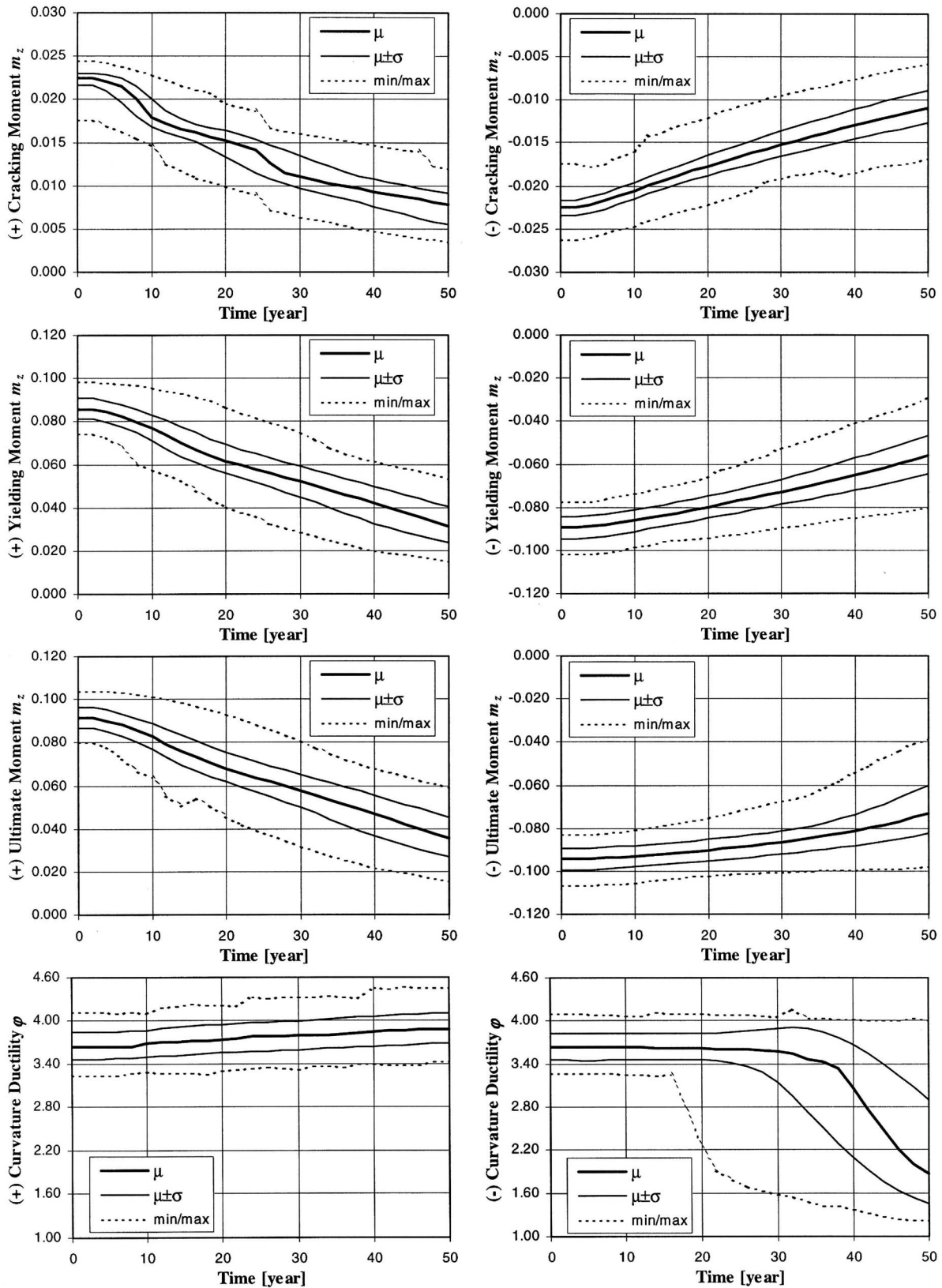

Fig. 5. Box-girder cross section undergoing diffusion. Time evolution of the structural performance indicators during the first 50 years of service life [$m_z = M_z / (f_c A_{c0} d_y)$; $\phi = \chi_u / \chi_y$]; mean μ (thick line), standard deviation σ from the mean μ (thin lines), minimum and maximum values (dotted lines).

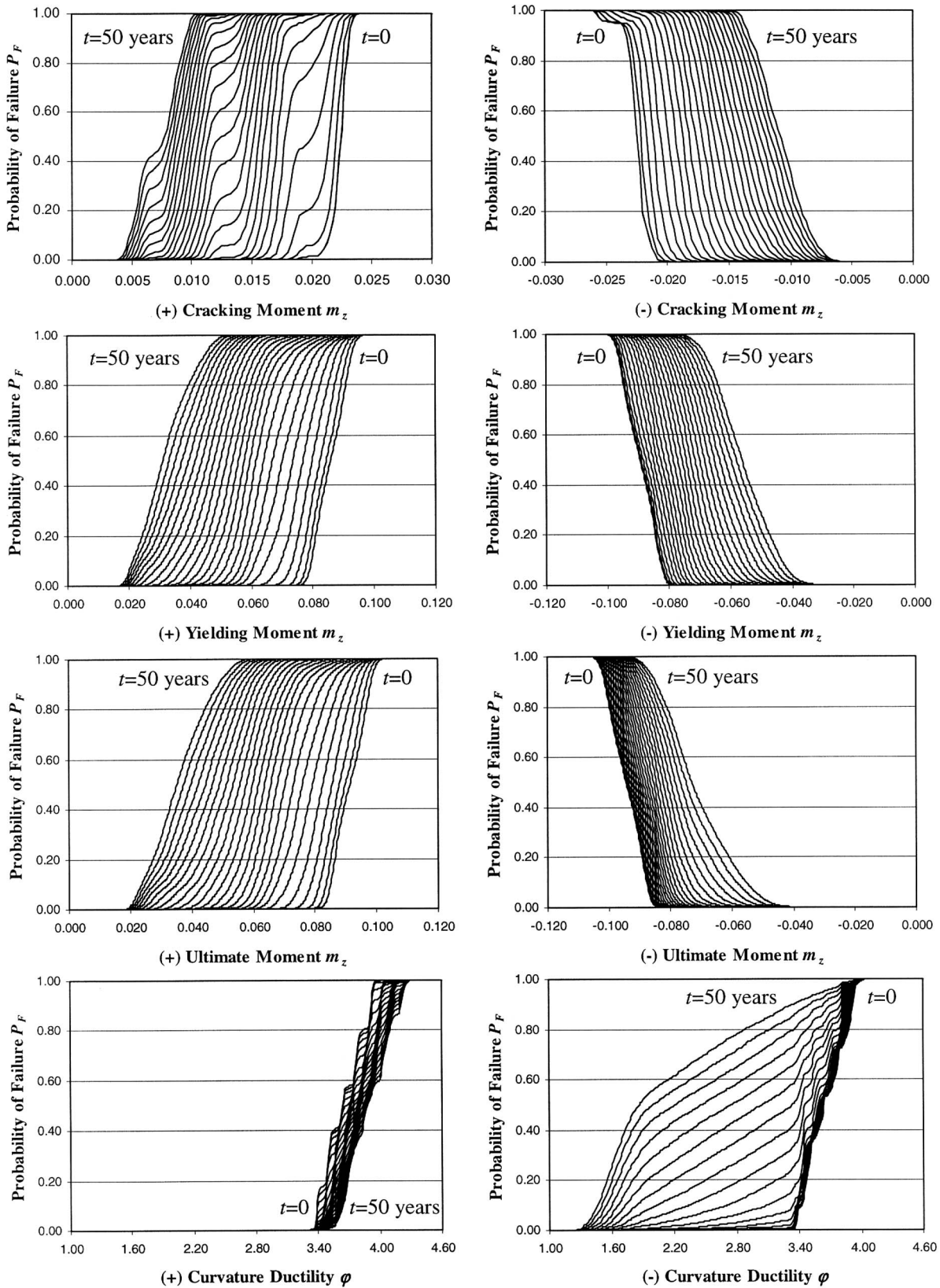

Fig. 6. Box-girder cross section undergoing diffusion. Time evolution of the probability curves during the first 50 years of service life ($\Delta t=2$ years): probability of failure P_F versus given deterministic target levels of the structural performance indicators [$m_z=M_z/(|f_c|A_c d_y)$; $\varphi=\chi_u/\chi_y$].

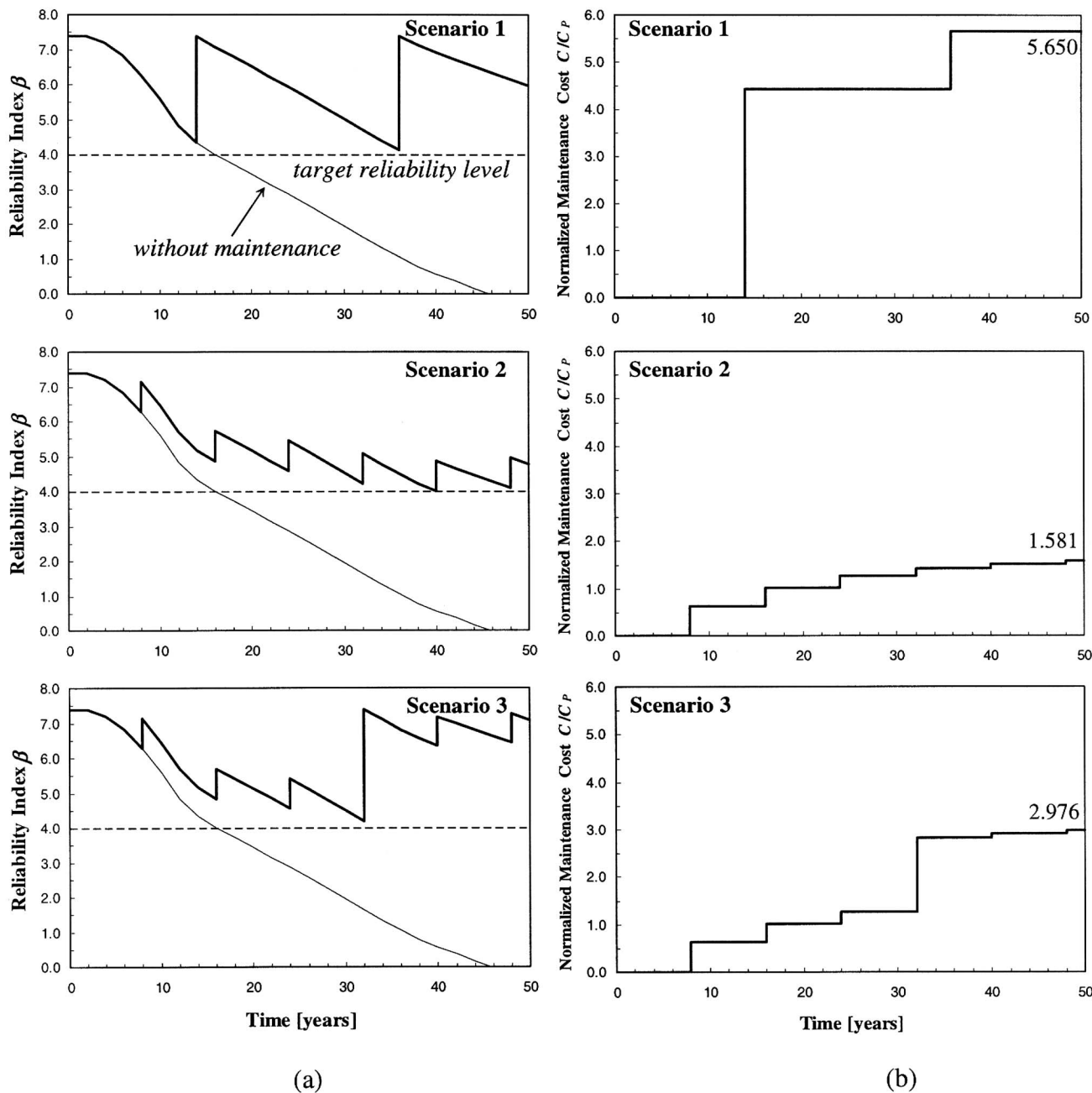

Fig. 7. Box-girder cross section undergoing diffusion. Maintenance planning with inspection time $\Delta t=2$ years: (a) time evolution of the reliability β and possible maintenance scenarios leading to a structural lifetime $T_a \geq 50$ years; and (b) time evolution of the normalized cumulative cost of maintenance associated with the different scenarios of structural rehabilitation.

cross section and $C(t)=\frac{1}{2}C_0$ along the internal one. Damage rates are defined by the nominal values $C_{cr}=0$, $C_c=C_s=C_0$, $\Delta t_c=5$ years, and $\Delta t_s=7.5$ years.

The diffusion process for the *nominal scenario* is highlighted in Fig. 11, which shows the maps of concentration $C(\mathbf{x},t)/C_0$ of the aggressive agent after 10, 20, 30, 40, and 50 years from the initial time of diffusion penetration. The mechanical damage induced by diffusion can be evaluated from diagrams of Fig. 12, which show the time evolution of the structural performance under the axial force $n=N/(f_c|A_{c0})=-0.122$, where $N=-100$ MN, in terms of the resistance diagrams of

the dimensionless bending moments $m_z=M_z/(f_c|A_{c0}d_y)$ and $m_y=M_y/(f_c|A_{c0}d_z)$.

In this application, the values of the ultimate bending moment computed along the following three loading paths under the axial force $N=-100$ MN are considered as probabilistic structural performance indicators: (1) $M_z \neq 0$, with $M_y=0$; (2) $M_y \neq 0$, with $M_z=0$; and (3) $M_z=M_y \equiv M_r$. With reference to a sample of 1,000 Monte Carlo simulations, Fig. 13(a) shows the time evolution of the statistical parameters (mean value μ , standard deviation σ , minimum and maximum values) of the dimensionless values of the resistant bending moments m_z , m_y , and $m_r=M_r/(f_c|A_{c0}d_r)$,

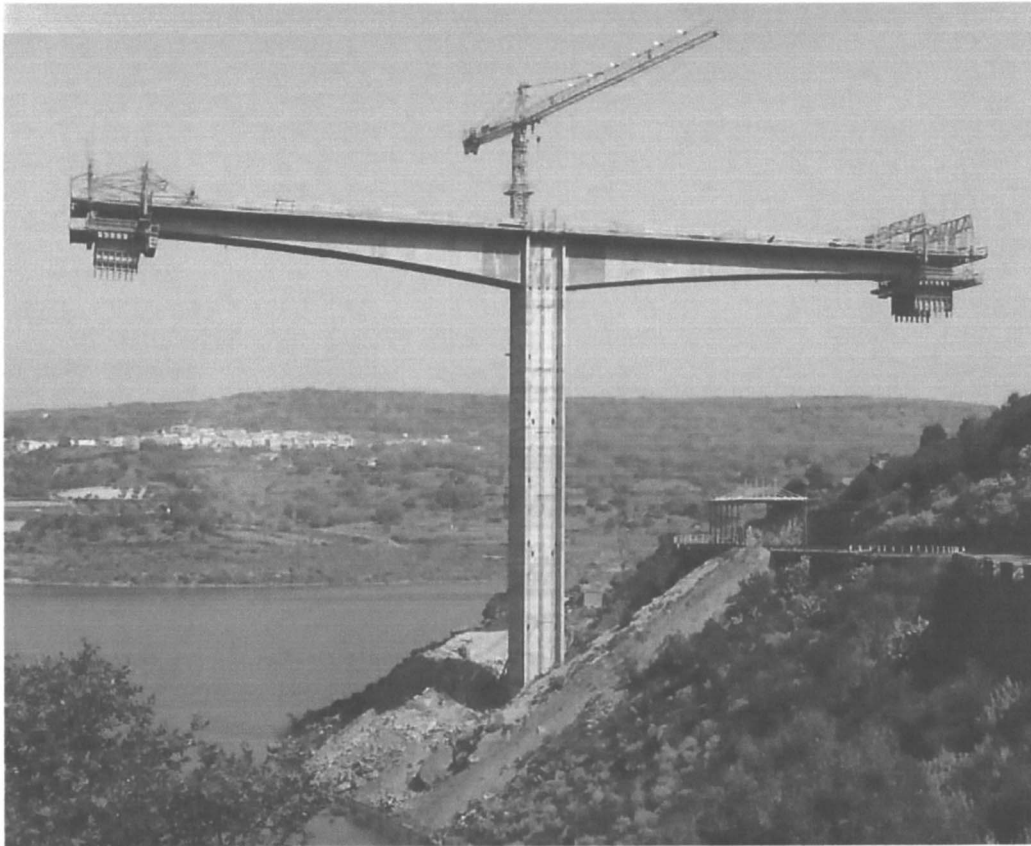

Fig. 8. Box-girder bridge with piers having box cross section (Martinez Y Cabrera 2002)

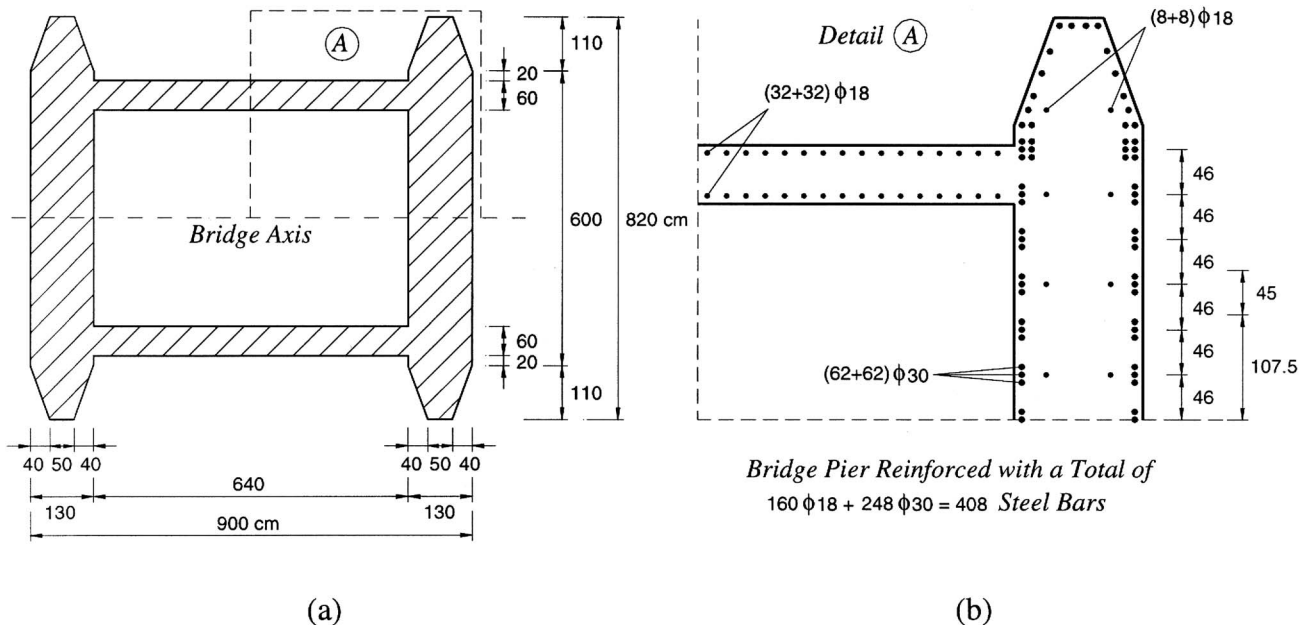

Fig. 9. Box cross section of a bridge pier: (a) geometry dimensions and (b) location of the reinforcement

with $d_r = d_z d_y [2/(d_z^2 + d_y^2)]^{0.5}$. The results of this simulation can be used to compute at each point in time the probability of failure $P_F = P_F(t)$ related to the randomness of the acting bending moments. As an example, the probability functions associated with a deterministic demand are carried out and the service life T_a^* associated with given target reliability levels P_F^* is then computed as a function of the expected deterministic values of the acting bending moments, as shown in Fig. 13(b). These curves allow to

assess the time-variant reliability of the cross section with respect to a given demand or, conversely, to assess the corresponding remaining service life which can be assured under prescribed reliability levels without maintenance.

In addition, as already shown for the previous case study, the results of the probabilistic analysis can be also used to plan a rehabilitation of the structure in order to achieve a given design value of the structural lifetime. As an example, Fig. 14 refers to

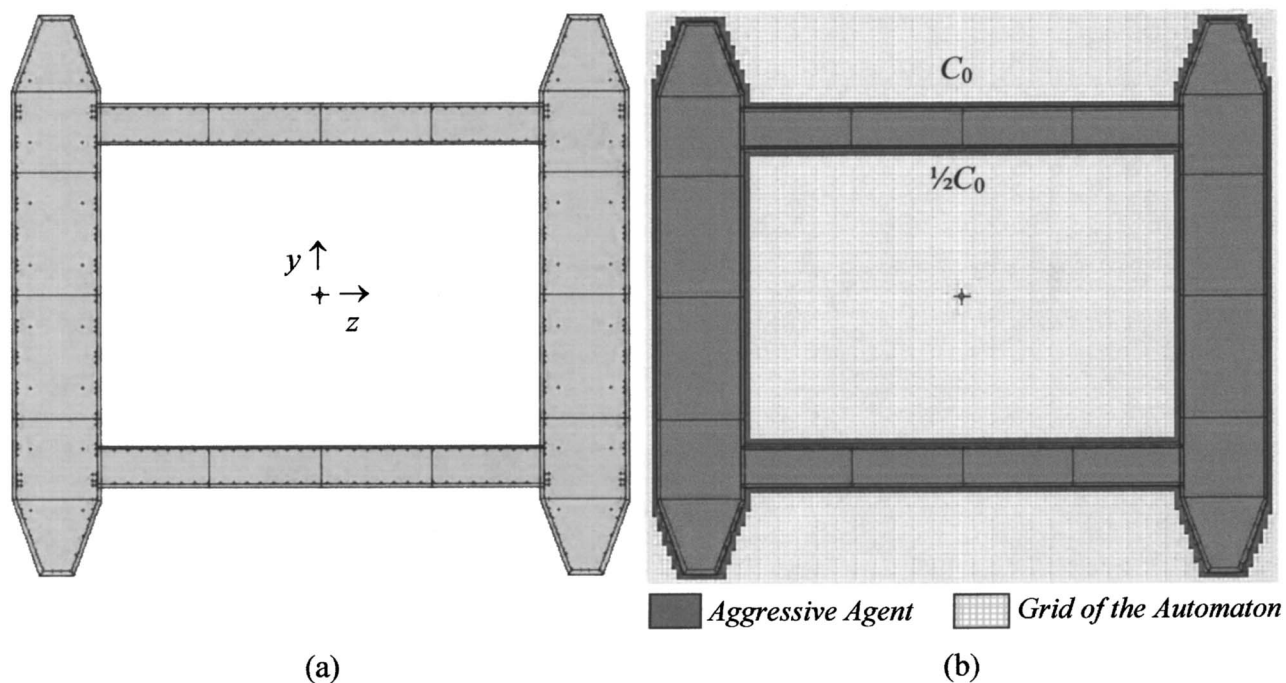

Fig. 10. Box cross section of a bridge pier: (a) discretization of the structural model; and (b) grid of the cellular automaton and location of the aggressive agent

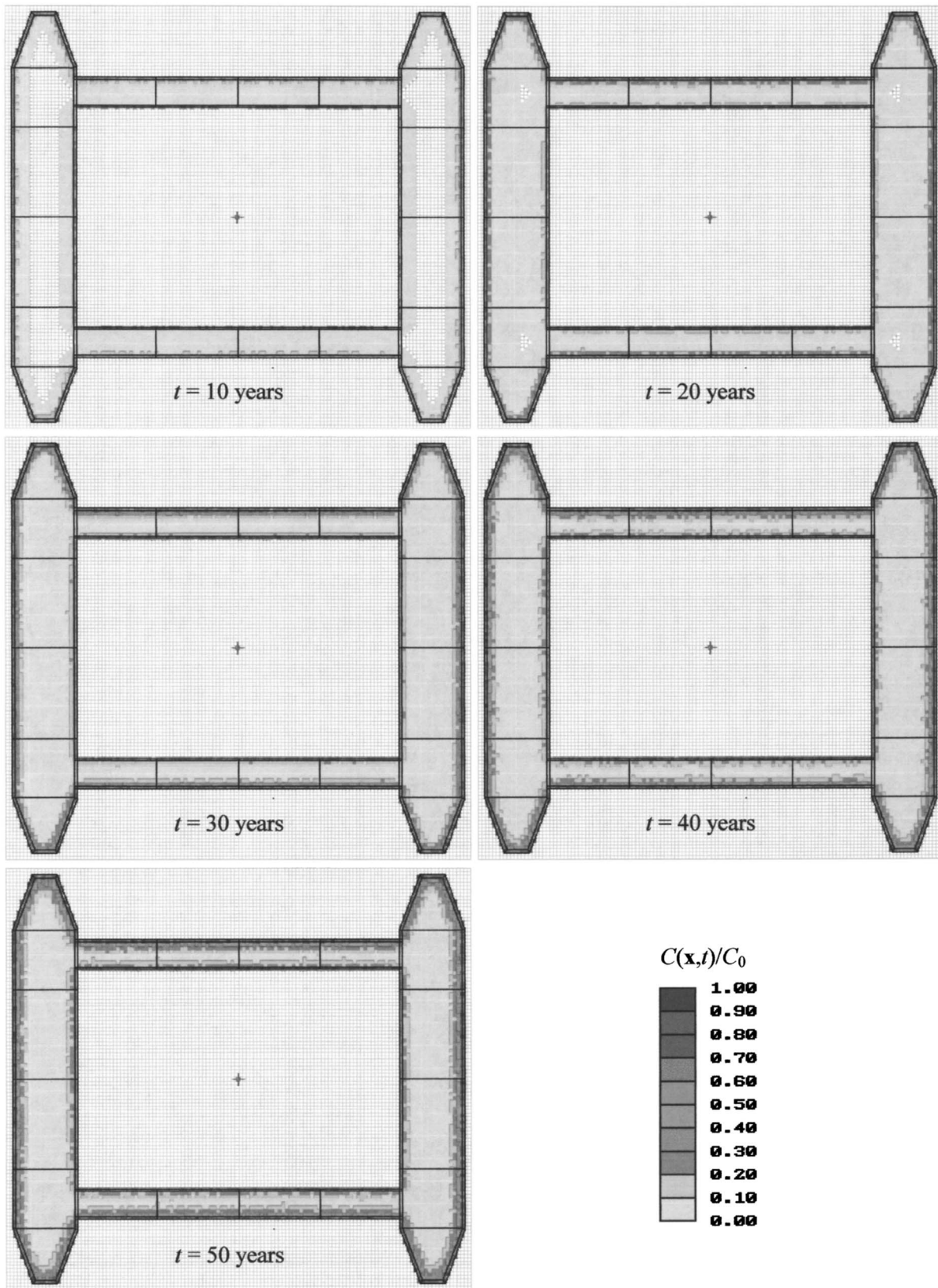

Fig. 11. Box-bridge pier undergoing diffusion. Map of the concentration $C(x,t)/C_0$ of the aggressive agent after 10, 20, 30, 40, and 50 years from the initial time of diffusion penetration (nominal scenario).

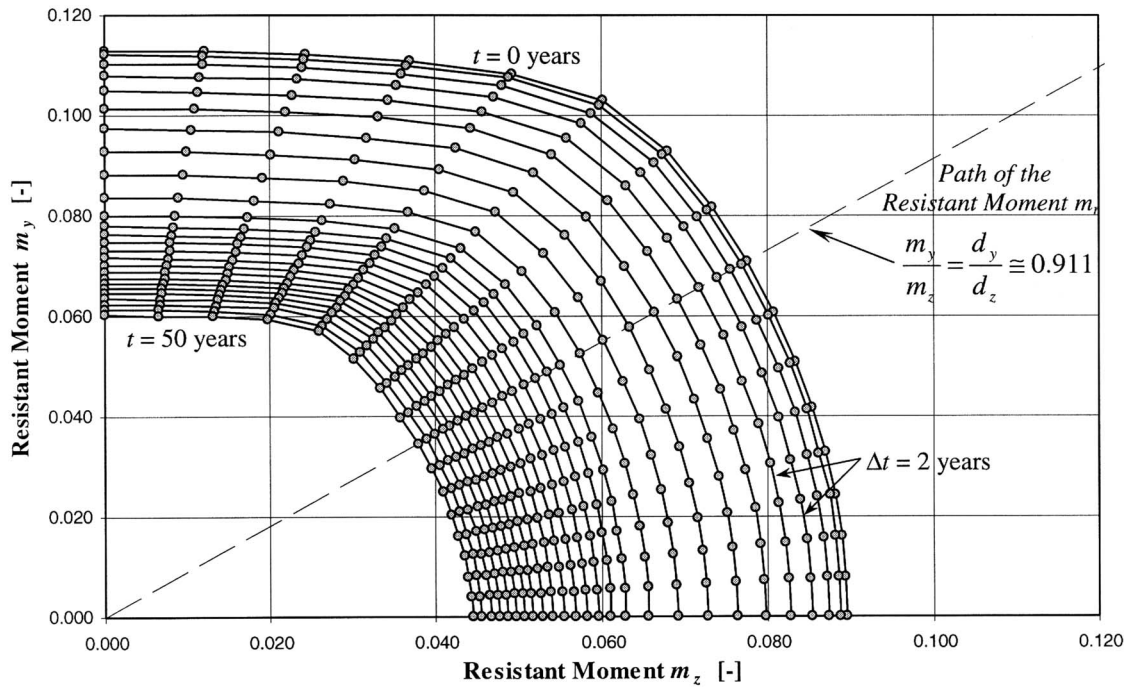

Fig. 12. Box-bridge pier undergoing diffusion. Time evolution ($\Delta t=2$ years) of the resistance diagrams m_z-m_y of the bending moments $m_z=M_z/(|f_c|A_{c0}d_y)$ and $m_y=M_y/(|f_c|A_{c0}d_z)$ under the axial force $n=N/(|f_c|A_{c0})=-0.122$ ($N=-100$ MN) (nominal scenario).

the time evolution of the reliability index $\beta(t)$ computed for the resistant dimensionless bending moment m_z by assuming a structural demand normally distributed with mean $\mu=0.050$, standard deviation $\sigma=0.10\mu$, and correlation coefficient $\rho=0$. With reference to a target level $\beta^*=4.0$, Fig. 14(a) shows three different scenarios of maintenance aimed to achieve a structural lifetime of at least 50 years. All scenarios are based on a two-year cycle of inspections, and when the target level β^* is approached, a rehabilitation is made in order to increase the reliability level.

The first scenario assumes essential interventions only, aimed to restore the initial reliability level β_0 . The second scenario assumes preventive interventions only, applied every 4 years by increasing the reliability index level by $\Delta\beta=0.55$. The third scenario assumes finally a mixed strategy with both essential and preventive interventions with $\Delta\beta=0.45$. Fig. 14(b) shows the corresponding time evolution of the cumulative costs C , normalized to the cost C_p of a single preventive intervention. The cumulative costs are computed by assuming a cost ratio between essential and preventive intervention $C_E/C_P=10$, and a discount rate of money $v=0.06$. The comparison among such diagrams highlights again the expected cost effectiveness of the preventive maintenance (Scenario 2).

Conclusions

1. A novel deterministic methodology for the assessment of the time-variant performance of deteriorating concrete structures subjected to the diffusive attack of external aggressive agents has been used as the basis for a probabilistic formulation of the lifetime durability analysis. The probabilistic assessment of the structural service life is performed via Monte Carlo simulation and the results of the simulation are used to select

a proper maintenance scenario.

2. The main novelty of the proposed approach is the use of a special class of evolutionary algorithms, called cellular automata, to investigate the deterioration processes induced by diffusion. The main advantages of these algorithms have been already highlighted in Biondini et al. (2004b). In this study, the attention has been mainly focused on the implementation of the proposed methodology in a probabilistic environment suitable for application to real structural systems, usually complex and involving many random variables. In this context, both effectiveness and feasibility of the proposed approach have been proved. This approach leads to a reliable assessment of the time-variant structural performance with respect to a given demand or, conversely, of the corresponding remaining service life which can be assured under prescribed reliability levels without maintenance. In addition, it has been shown how the results of the probabilistic analysis can also be used to plan a rehabilitation of the structure in order to achieve a prescribed target value of the structural lifetime.
3. The accuracy of the results depends on the values of the material parameters which define both the diffusive and damage processes. The model used to evaluate the effects of maintenance interventions on the structural reliability does not account for the actual damage state of the system. Further developments aimed to achieve a proper calibration of the material parameters and of their probabilistic distributions, as well as to define more proper maintenance models and to integrate monitoring interventions, are then required. However, despite the necessity of such developments, the proposed approach is proven to represent a powerful engineering tool in both reliability assessment and maintenance planning of deteriorating concrete structures.

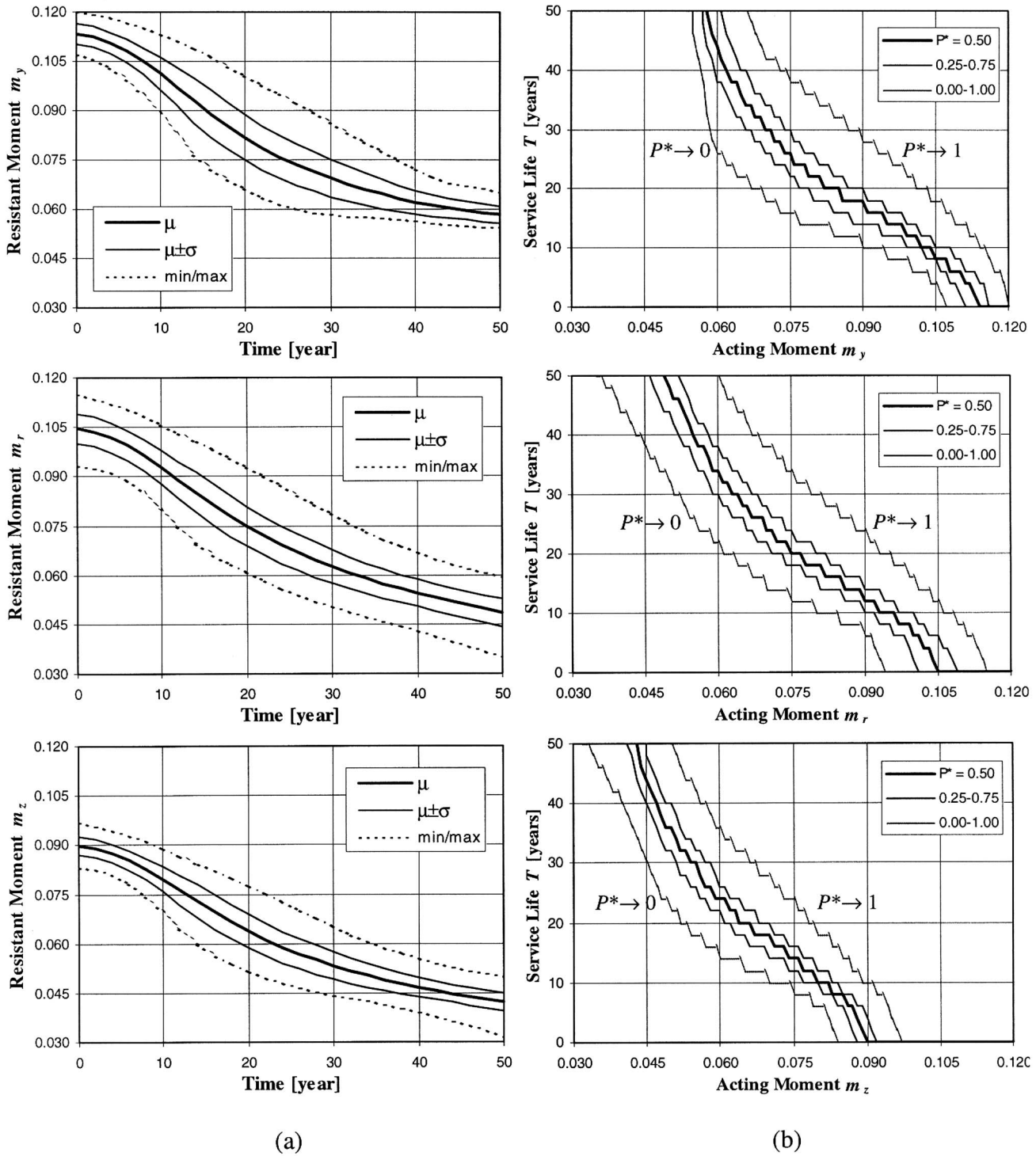

Fig. 13. Box-bridge pier undergoing diffusion. (a) Time evolution of the resistance bending moments: mean μ (thick line), standard deviation σ from the mean μ (thin lines), minimum and maximum values (dotted lines). (b) Service life associated to given probability of failure P^* versus given target levels of the resistance bending moments.

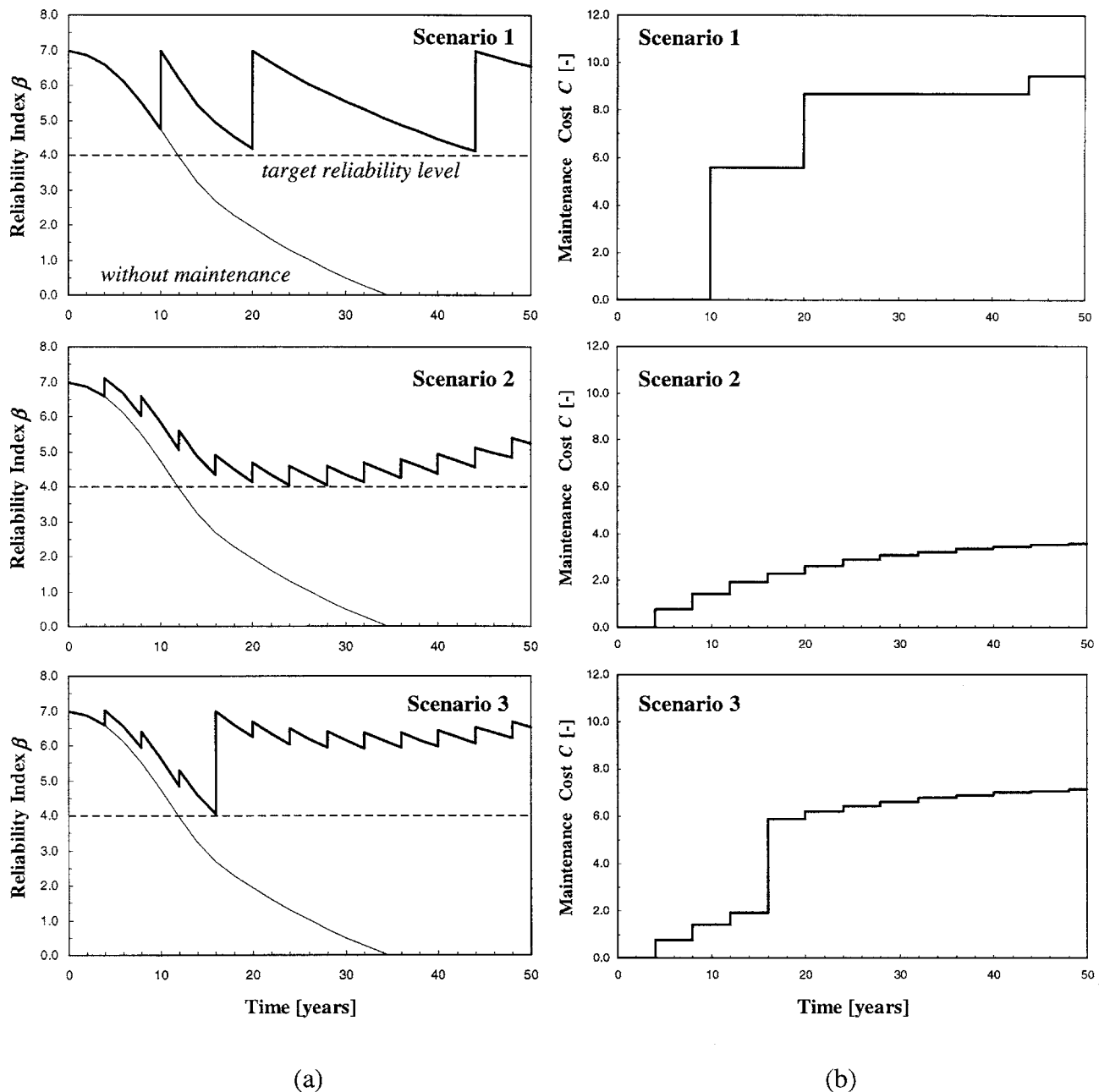

Fig. 14. Box-bridge pier undergoing diffusion. Maintenance planning with inspection time $\Delta t=2$ years: (a) Time evolution of the reliability index β and possible maintenance scenarios leading to a structural lifetime $T_a \geq 50$ years. (b) Time evolution of the normalized cumulative cost of the different maintenance scenarios of structural rehabilitation (inspection time $\Delta t=2$ years).

Acknowledgments

The study presented in this paper is supported by research funds MIUR-COFIN2002 from the Department of Structural Engineering, Politecnico di Milano, Italy, and the Department of Structural and Geotechnical Engineering, University of Rome "La Sapienza," Italy. Part of the research has been developed while the first writer visited the Department of Civil, Environmental and Architectural Engineering, University of Colorado at Boulder, Colo. The third writer acknowledges the support of the U.S. National Science Foundation through Grant Nos. CMS-021790 and CMS-0509772. The opinions and conclusions presented in the

paper are those of the writers and do not necessarily reflect the views of the sponsoring organization.

References

- Ardigó, C., and Motta, S. (2002). "Durability analysis of concrete structures subjected to the diffusive action of external aggressive agents." Degree thesis, Dept. of Structural Engineering, Politecnico di Milano, Milan, Italy (In Italian).
- Biondini, F., Bontempi, F., and Frangopol, D. M. (2004a). "Probabilistic performance of concrete structures in aggressive environments." *Life-cycle performance of deteriorating structures*, D. M. Frangopol,

- E. Brühwiler, M. H. Faber, and B. Adey, eds., ASCE, Reston, Va., 83–91.
- Biondini, F., Bontempi, F., Frangopol, D. M., and Malerba, P. G. (2004b). “Cellular automata approach to durability analysis of concrete structures in aggressive environments.” *J. Struct. Eng.*, 130(11), 1724–1737.
- Biondini, F., Bontempi, F., Frangopol, D. M., and Malerba, P. G. (2004c). “Tools for service life evaluation and optimal maintenance of concrete bridges.” *Proc., 2nd Int. Conf. on Bridge Maintenance, Safety and Management (IABMAS'04)*, Kyoto, Japan, E. Watanabe, D. M. Frangopol, and T. Utsunomija, eds., Balkema, Rotterdam, The Netherlands.
- CEB. (1992). *Durable concrete structures—Design guide*, Thomas Telford, London.
- Glicksman, M. E. (2000). *Diffusion in solids*, Wiley, New York.
- Kong, J. S., and Frangopol, D. M. (2003). “Life-cycle reliability-based maintenance cost optimization of deteriorating structures with emphasis on bridges.” *J. Struct. Eng.*, 129(6), 818–828.
- Malerba, P. G., ed. (1998). *Limit and nonlinear analysis of reinforced concrete structures*, International Centre for Mechanical Sciences (CISM), Udine, Italy (in Italian).
- Martinez Y Cabrera, F. (2002). *Collected papers—In memory of Martinez Y. Cabrera*, Politecnico di Milano, Italy.
- Neves, L. C., Frangopol, D. M., and Hogg, V. (2003). “Condition-reliability-cost interaction in bridge maintenance.” *Applications of statistics and probability in civil engineering*, A. Der Kiureghian, S. Madanat, and J. M. Pestana, eds., Millpress, Rotterdam, The Netherlands, 1117–1122.
- Wolfram, S. (1994). *Cellular automata and complexity—Collected papers*, Addison-Wesley, Reading, Mass.